

CDF 40 DEHUMIDIFIER

Function

The CDF 40 is an energy efficient and quiet dehumidifier. It works in accordance with the condensation principle. A fan draws the humid air into the dehumidifier and through an evaporator coil. When passing through the evaporator the air is cooled down to below its dew point temperature, and its content of water vapour is condensed into water, which falls into the drip tray and then is led from the drip tray to a drain. The cold, dry air is then passed over the condenser coil where it is re-heated, before leaving the unit at a temperature, which is approx. 5°C higher than at the inlet.

Applications

- Archives
- Museums
- Churches
- Changing rooms
- Waterworks

FEATURES

Dehumidifier

- Built into a strong and robust powder coated hot galvanized sheet metal cabinet
- Evaporator and condenser coils are epoxy-coated for high corrosion resistance
- Fixed to the wall by means of a wall mounting strip supplied with the unit
- Condensate outlet located at the bottom. Outlet stub can be connected to a ¾" hose
- Outside connection to mains

Control

- Built in electronic hygostat and thermostat
- Integrated ON/OFF control of humidity and temperature (electric or water heating coils as accessories)
- 0-VOLT connection for alarm
- 230 V for control valve, exhaust fan and pump/boiler
- RS 485 gate for BMS (Modbus)

Diodes

- BLUE: Power connected, standby mode
- GREEN: Compressor ON, deicing
- YELLOW: Remote pairing mode
- RED: Errors

Defrosting

Active, demand-controlled defrosting is incorporated in the electronic control.

Service

For easy service the refrigerant circuit is supplied with a service valve. The PCB has a USB gate for history data logging for easy fault finding.

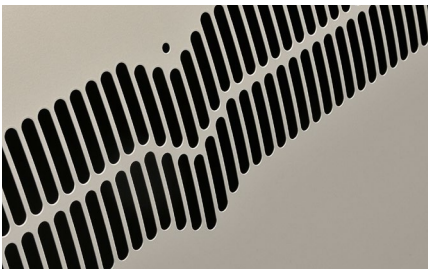

TECHNICAL DATA

Model	CDF 40
Operating range – humidity	40 – 100 %RH
Operating range – temperature	3 – 32°C
Air volume	400 m ³ /h
Power supply	1x230 V/50 Hz
Max. ampere consumption	3,4 A
Max. power consumption	0,78 kW
Refrigerant	R407C
Quantity of refrigerant	0,7 kg
Compressor	Rotary
Fan	Radial
Sound level (at 1 metre)	46 dB(A)
Weight	56,5 kg
Filter	G3 PPI 15
Colour (Cabinet/Front)	RAL 9005/9006
Protection class	IPX4
Corrosion protection in accordance with EN/ISO 12944-2	C4

CAPACITY CURVES

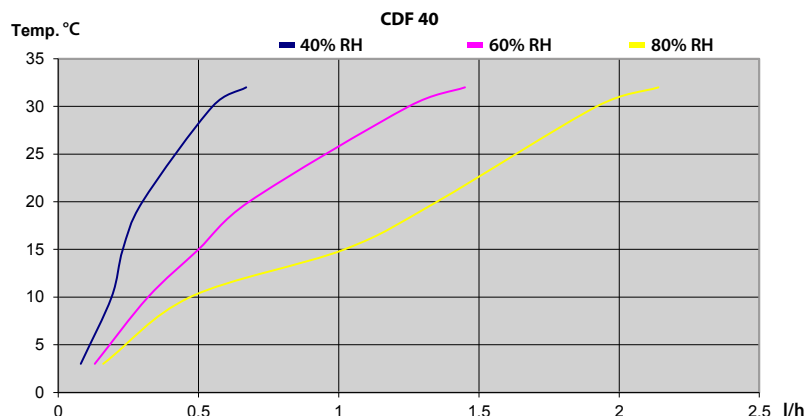

Specific energy consumption (SEC):
0,80 kWh/l at 20°C & 60% RH

INSTALLATION

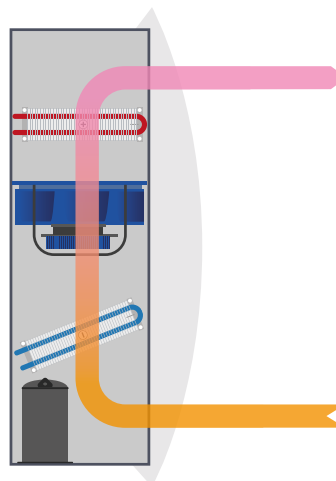

DIMENSIONS CDF 40

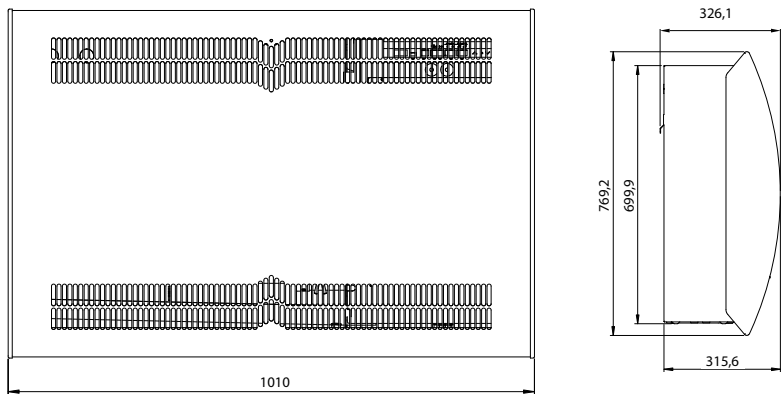

Drain outlet position

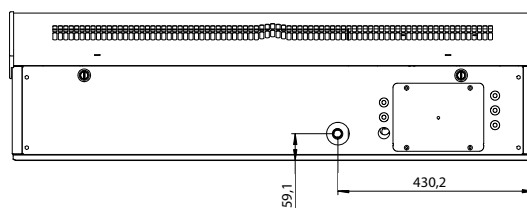

Recommended installation of CDF 40

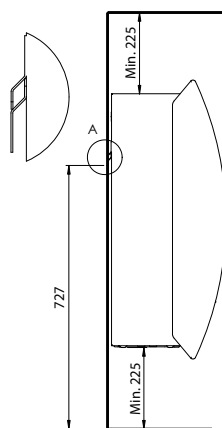

Floor mounting kit

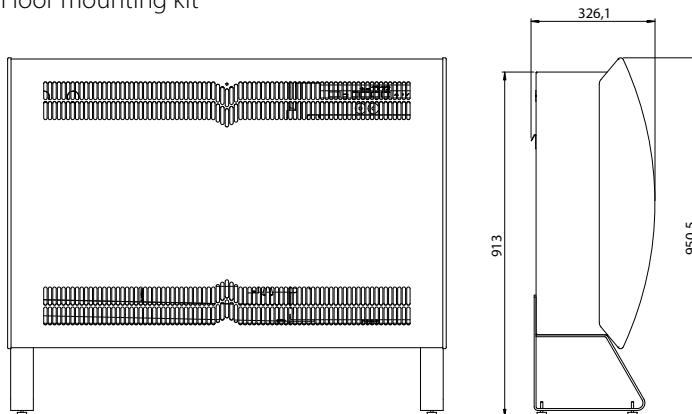

Accessories

- Wireless remote control DRC1
- Floor mounting kit
- Water heating coils
- Control valve for water heating coils
- Electric heating coils
- Exhaust fans

All dimensions are in mm.

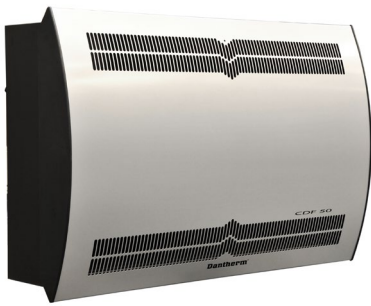

CDF 50 DEHUMIDIFIER

Function

The CDF 50 is an energy efficient and quiet dehumidifier. It works in accordance with the condensation principle. A fan draws the humid air into the dehumidifier and through an evaporator coil. When passing through the evaporator the air is cooled down to below its dew point temperature, and its content of water vapour is condensed into water, which falls into the drip tray and then is led from the drip tray to a drain. The cold, dry air is then passed over the condenser coil where it is re-heated, before leaving the unit at a temperature, which is approx. 5°C higher than at the inlet.

Applications

- Archives
- Museums
- Churches
- Changing rooms
- Waterworks

FEATURES

Dehumidifier

- Built into a strong and robust powder coated hot galvanized sheet metal cabinet
- Evaporator and condenser coils are epoxy-coated for high corrosion resistance
- Fixed to the wall by means of a wall mounting strip supplied with the unit
- Condensate outlet located at the bottom. Outlet stub can be connected to a ¾" hose
- Outside connection to mains

Control

- Built in electronic hygostat and thermostat
- Integrated ON/OFF control of humidity and temperature (electric or water heating coils as accessories)
- 0-VOLT connection for alarm
- 230 V for control valve, exhaust fan and pump/boiler
- RS 485 gate for BMS (Modbus)

Diodes

- BLUE: Power connected, standby mode
- GREEN: Compressor ON, deicing
- YELLOW: Remote pairing mode
- RED: Errors

Defrosting

Active, demand-controlled defrosting is incorporated in the electronic control.

Service

For easy service the refrigerant circuit is supplied with a service valve. The PCB has a USB gate for history data logging for easy fault finding.

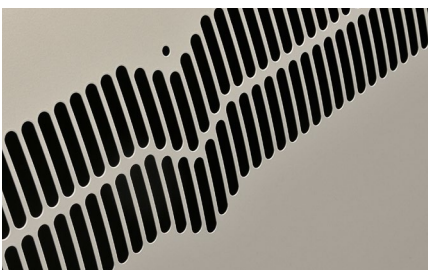

TECHNICAL DATA

Model	CDF 50
Operating range – humidity	40 – 100 %RH
Operating range – temperature	3 – 32°C
Air volume	680 m ³ /h
Power supply	1x230 V/50 Hz
Max. ampere consumption	4,7 A
Max. power consumption	1,08 kW
Refrigerant	R407C
Quantity of refrigerant	0,9 kg
Compressor	Rotary
Fan	Radial
Sound level (at 1 metre)	47 dB(A)
Weight	65 kg
Filter	G3 PPI 15
Colour (Cabinet/Front)	RAL 9005/9006
Protection class	IPX4
Corrosion protection in accordance with EN/ISO 12944-2	C4

CAPACITY CURVES

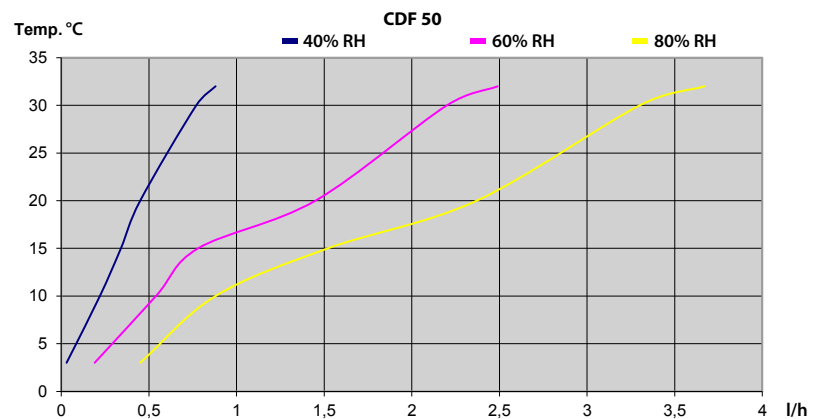

Specific energy consumption (SEC):
0,63 kWh/l at 20°C & 60% RH

INSTALLATION

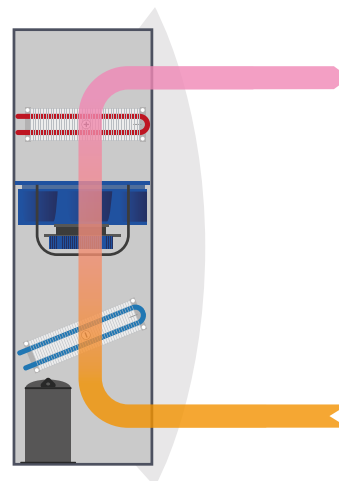

DIMENSIONS CDF 50

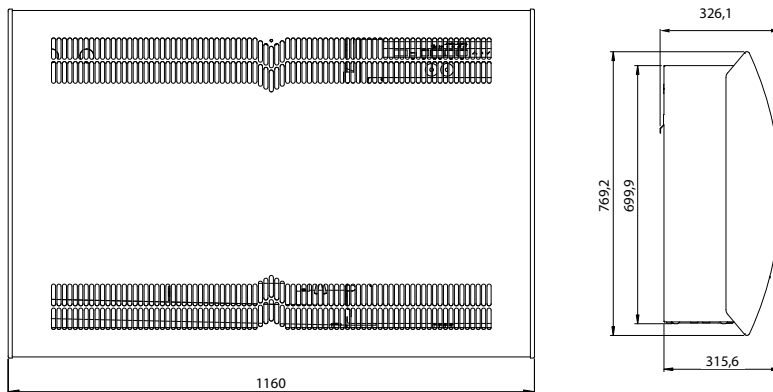

Drain outlet position

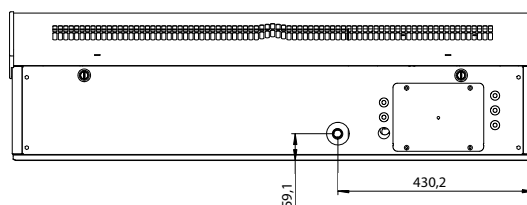

Recommended installation of CDF 50

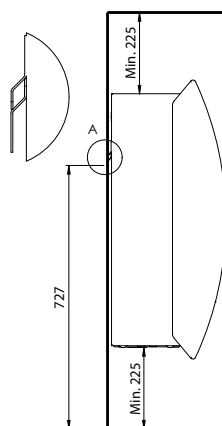

Floor mounting kit

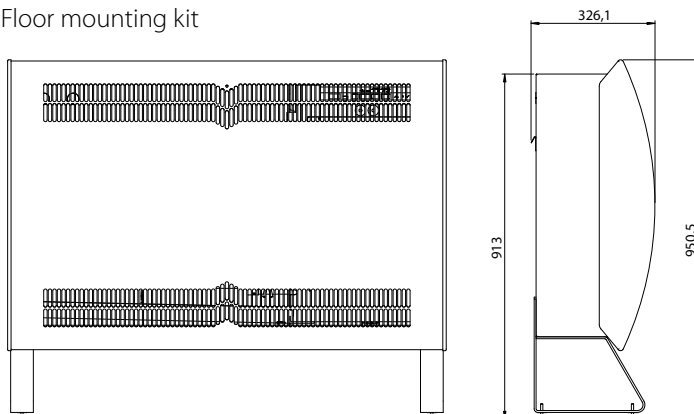

Accessories

- Wireless remote control DRC1
- Floor mounting kit
- Water heating coils
- Control valve for water heating coils
- Electric heating coils
- Exhaust fans

All dimensions are in mm.

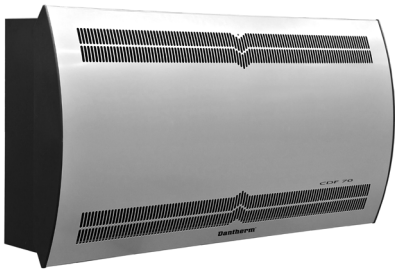

CDF 70 DEHUMIDIFIER

Function

The CDF 70 is an energy efficient and quiet dehumidifier. It works in accordance with the condensation principle. A fan draws the humid air into the dehumidifier and through an evaporator coil. When passing through the evaporator the air is cooled down to below its dew point temperature, and its content of water vapour is condensed into water, which falls into the drip tray and then is led from the drip tray to a drain. The cold, dry air is then passed over the condenser coil where it is re-heated, before leaving the unit at a temperature, which is approx. 5°C higher than at the inlet.

Applications

- Archives
- Museums
- Churches
- Changing rooms
- Waterworks

FEATURES

Dehumidifier

- Built into a strong and robust powder coated hot galvanized sheet metal cabinet
- Evaporator and condenser coils are epoxy-coated for high corrosion resistance
- Fixed to the wall by means of a wall mounting strip supplied with the unit
- Condensate outlet located at the bottom. Outlet stub can be connected to a ¾" hose
- Outside connection to mains

Control

- Built in electronic hygostat and thermostat
- Integrated ON/OFF control of humidity and temperature (electric or water heating coils as accessories)
- 0-VOLT connection for alarm
- 230 V for control valve, exhaust fan and pump/boiler
- RS 485 gate for BMS (Modbus)

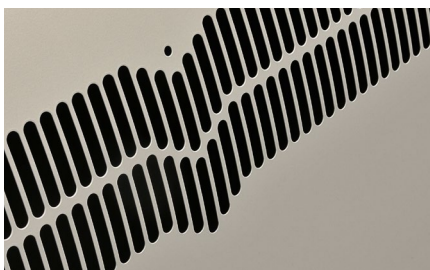

Diodes

- BLUE: Power connected, standby mode
 GREEN: Compressor ON, deicing
 YELLOW: Remote pairing mode
 RED: Errors

Defrosting

Active, demand-controlled defrosting is incorporated in the electronic control.

Service

For easy service the refrigerant circuit is supplied with a service valve. The PCB has a USB gate for history data logging for easy fault finding.

TECHNICAL DATA

Model	CDF 70
Operating range – humidity	40 – 100 %RH
Operating range – temperature	3 – 32°C
Air volume	900 m ³ /h
Power supply	1x230 V/50 Hz
Max. ampere consumption	6,5 A
Max. power consumption	1,5 kW
Refrigerant	R407C
Quantity of refrigerant	1,2 kg
Compressor	Rotary
Fan	Radial
Sound level (at 1 metre)	50 dB(A)
Weight	75,5 kg
Filter	G3 PPI 15
Colour (Cabinet/Front)	RAL 9005/9006
Protection class	IPX4
Corrosion protection in accordance with EN/ISO 12944-2	C4

CAPACITY CURVES

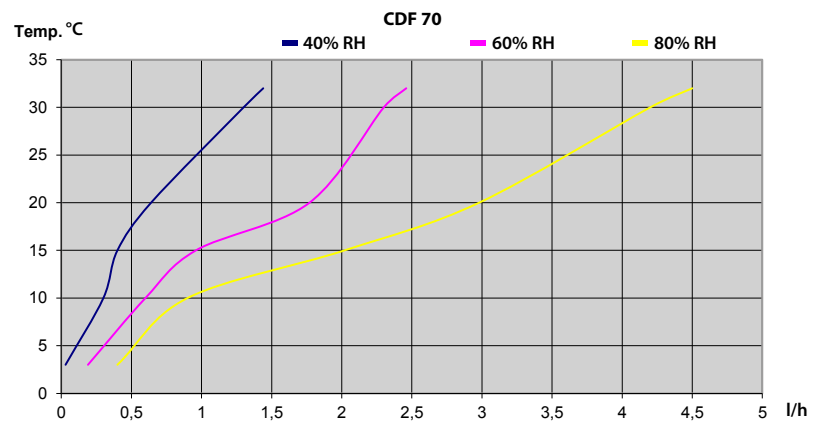

Specific energy consumption (SEC):
0,58 kWh/l at 20°C & 60% RH

INSTALLATION

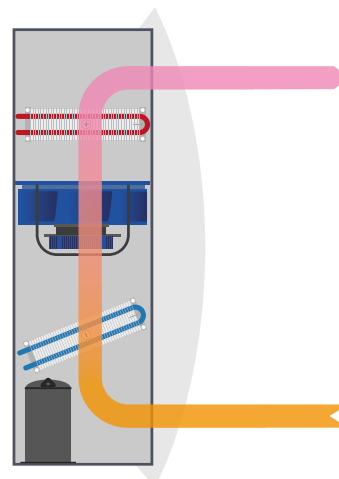

DIMENSIONS CDF 70

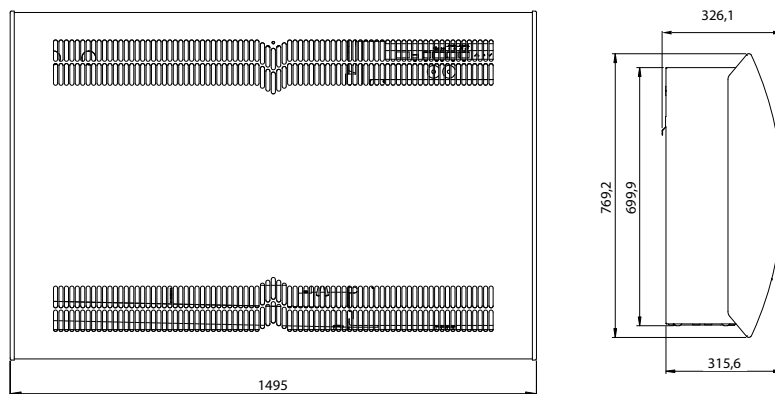

Drain outlet position

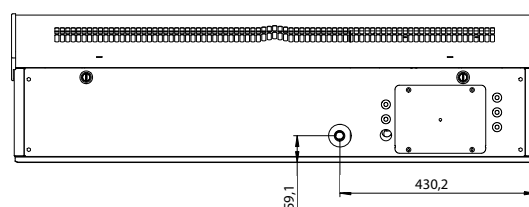

Recommended installation of CDF 70

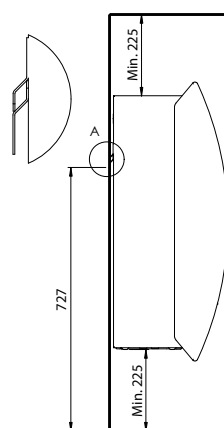

Floor mounting kit

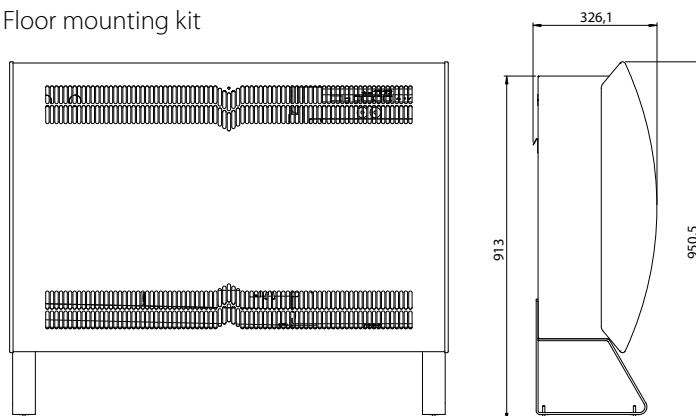

Accessories



- Wireless remote control DRC1
- Floor mounting kit
- Water heating coils
- Control valve for water heating coils
- Electric heating coils
- Exhaust fans

All dimensions are in mm.

ACCESSORIES CDF 10 – CDF 40 – CDF 50 – CDF 70

Illustration	Accessory	Description	CDF-type	Dantherm No.
	Watertank	White or grey	CDF 10	351615
	Remote control, DRC1	<p>DRC1 is a wireless RH and temperature controller</p> <p>Frequency: 433 mhz</p> <p>Range up to 50 m depending on the conditions</p> <p>Protection class: IP 20</p> <p>Functionalities:</p> <ul style="list-style-type: none"> • Reading and setting of RH and temperature, alarms and service information • Locking of settings 	CDF 40 CDF 50 CDF 70	093455
	Floor mounting kit, 2 pcs.- black	Each bracket to be mounted on each side of the dehumidifier	CDF 40 CDF 50 CDF 70	094332
	Water heating coil 3,2 kW*)	Comprises water heating coil, flexible hose, fittings and gasket	CDF 40	094333
	Water heating coil 5,1 kW*)	*at 80/60° C	CDF 50	094334
	Water heating coil 7,4 kW*)	(See technical specifications for water heating coils on separate page)	CDF 70	094335
	DN 10 control valve and actuator for water heating coils	Comprises valve and actuator 230 V, ON/OFF (180 seconds from closed to fully open), incl. union nut for Ø 12 cu tube	CDF 40 CDF 50 CDF 70	094340

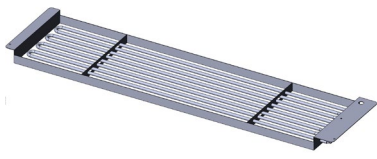
ACCESSORIES CDF 10 – CDF 40 – CDF 50 – CDF 70

Illustration	Accessory	Description	CDF-type	Dantherm No.
	Electric heating coil 2 kW	Comprises electric heating coil, relays and electric wires	CDF 40	094336
	Electric heating coil 3,5 kW		CDF 50	094337
	Electric heating coil 5 kW		CDF 70	094338
	Exhaust fan, Q = 97 m3/h	The exhaust fan can be used in combination with the CDF to either increase dehumidification capacity or establish outdoor air supply.	CDF 40 CDF 50 CDF 70	094339
	Exhaust fan, Q = 185 m3/h		Relay and electric wire are included.	CDF 40 CDF 50 CDF 70

ACCESSORIES CDF 40 - CDF 50 - CDF 70

Water heating coils - calculations at room temperature = 20°C; 50% RH

CDF 40	Q=400 m³/h						
Water temperature	°C	82/71	80/60	70/35	90/70	60/40	55/45
Capacity	kW	3,85	3,19	1,16	3,94	1,64	1,91
Water flow rate	l/sec.	0,09	0,04	0,01	0,05	0,02	0,05
Water pressure drop	kPa	15,5	3,9	0,3	5,5	1,3	5,7
Water velocity	m/sec.	1,22	0,56	0,11	0,69	0,28	0,66
Air flow rate	m ³ /sec.	0,11	0,11	0,11	0,11	0,11	0,11
Inlet temperature	°C	82	80	70	90	60	55
Outlet temperature	°C	71	60	35	70	40	45
Air pressure drop	Pa	8	8	8	8	8	8
Connection tube	mm	12	12	12	12	12	12

CDF 50	Q=680 m³/h						
Water temperature	°C	82/71	80/60	70/35	90/70	60/40	55/45
Capacity	kW	6,11	5,12	2,42	6,29	2,75	3,08
Water flow rate	l/sec.	0,14	0,06	0,02	0,08	0,03	0,08
Water pressure drop	kPa	42,2	10,6	1,1	14,9	3,8	15,6
Water velocity	m/sec.	1,94	0,06	0,24	1,1	0,48	1,07
Air flow rate	m ³ /sec.	0,19	0,19	0,19	0,19	0,19	0,19
Inlet temperature	°C	82	80	70	90	60	55
Outlet temperature	°C	71	60	35	70	40	45
Air pressure drop	Pa	10	10	10	10	10	10
Connection tube	mm	12	12	12	12	12	12

CDF 70	Q=900 m³/h						
Water temperature	°C	82/71	80/60	70/35	90/70	60/40	55/45
Capacity	kW	8,74	7,43	3,86	9,07	4,12	4,47
Water flow rate	l/sec.	0,19	0,09	0,03	0,11	0,05	0,11
Water pressure drop	kPa	108,1	27,7	3,4	38,7	10,3	40,7
Water velocity	m/sec.	2,78	1,3	0,38	1,59	0,71	1,55
Air flow rate	m ³ /sec.	0,25	0,25	0,25	0,25	0,25	0,25
Inlet temperature	°C	82	80	70	90	60	55
Outlet temperature	°C	71	60	35	70	40	45
Air pressure drop	Pa	8	8	8	8	8	8
Connection tube	mm	12	12	12	12	12	12